

REVISION HISTORY			
DATE	REV.	DESCRIPTION	BY
2023/5/23	A	INITIAL RELEASE	PXiong

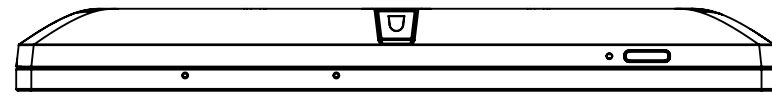

7.921
[201.20]

0.854
[21.70]

2.953
[75]

5.862
[148.90]

2.953
[75]

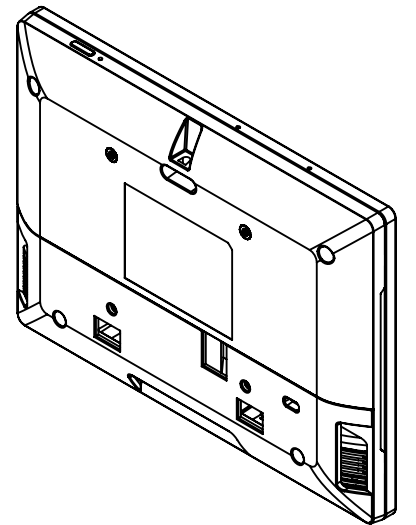
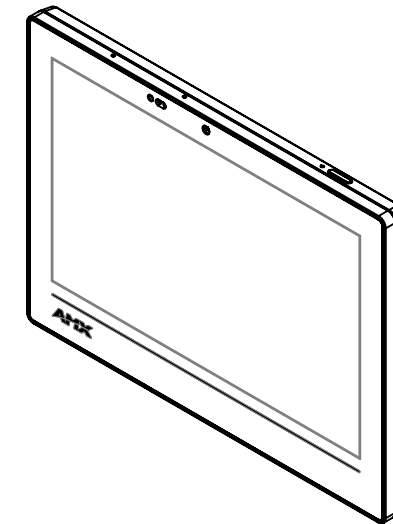
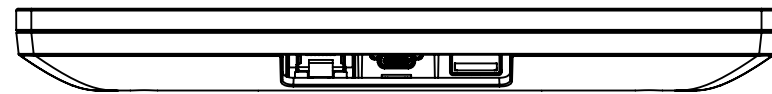
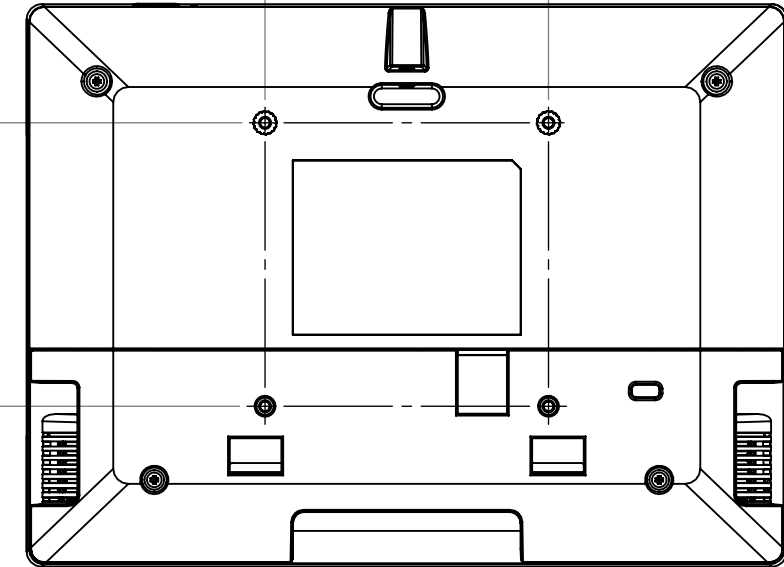
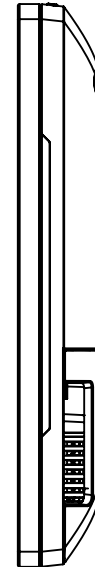
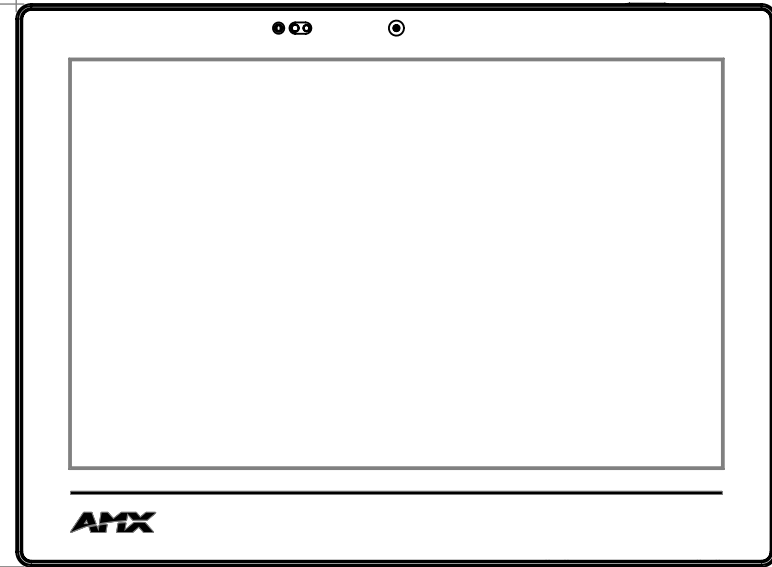

- NOTES:
1. Unit: inch / [mm]
 2. Detailed dimension refer to DXF/DWG files.

2023 © HARMAN INTERNATIONAL INDUSTRIES, INCORPORATED. ALL RIGHTS RESERVED. DO NOT USE, DISCLOSE, SELL, REPRODUCE, PUBLISH OR MODIFY WITHOUT AUTHORIZED WRITTEN HARMAN PERMISSION.

ROHS
RESTRICTION OF HAZARDOUS SUBSTANCES
ALL MATERIALS USED IN THIS PART MUST BE ROHS COMPLIANT.
SUPPLIER SHALL PROVIDE A CERTIFICATE OF ROHS COMPLIANCE WITH THE FIRST ARTICLE.

THIRD ANGLE PROJECTION

DRAWN BY
PXiong

DESIGNED BY

PROJECT MANAGER/ENGINEER

DATE
2023/5/23

DATE

HARMAN

TITLE
DWG, PICTORIAL, AMX-UTP0811

NO. **AMX-UTP0811** REV **A**

SIZE **B** SCALE **1:2** DO NOT SCALE DRAWING SHEET **1** OF **1**

DIMENSIONS SHOWN ARE FOR REFERENCE AND INSPECTION ONLY. REFER TO CAD MODEL PROVIDED WITH THIS DRAWING FOR OVERALL DEFINITION OF PART GEOMETRY.